

FL3015 Fiber

The all new FL3015 fiber laser cutting system is the latest high quality fiber laser produced by HK. It features a cutting carriage with dual servo motors and additional frames to prevent whipping with a brand new zooming cutting head featuring SMART-CUT technology. The FL3015 has a wide open side door for flexible cutting of various sheet sizes with a rotary axis as an option for tube cutting.

Wide-Open Structure with Long Cutting Bridge

- Wide-open side door structure enables the operator to easily access the work table and perform various cutting applications, jig & fixture work.

Strong & Ultra-Light Cutting Bridge

- Increased Rigidity reduces Vibration resulting in higher machine dynamics and performance. Distortion rate under high dynamic movement is reduced by 10x.
- Honeycomb designed frame allows for a light & strong gantry system that promotes speed & stability.
- Built in gas delivery system at cutting bridge.

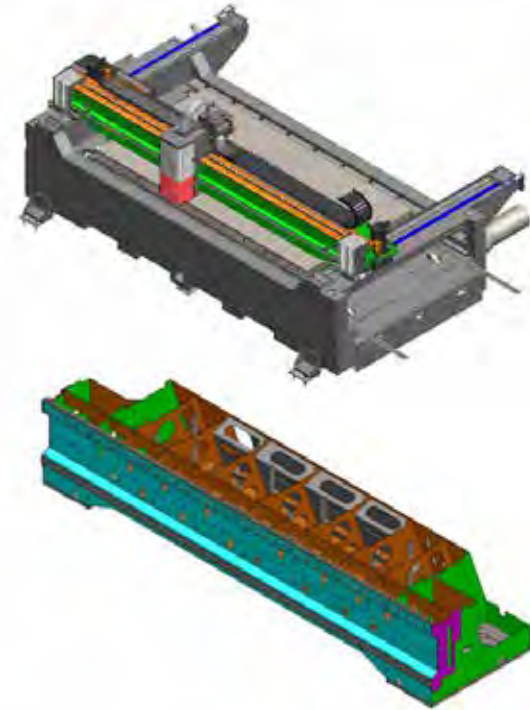

Multi-Functional High Speed Fiber Laser Machine

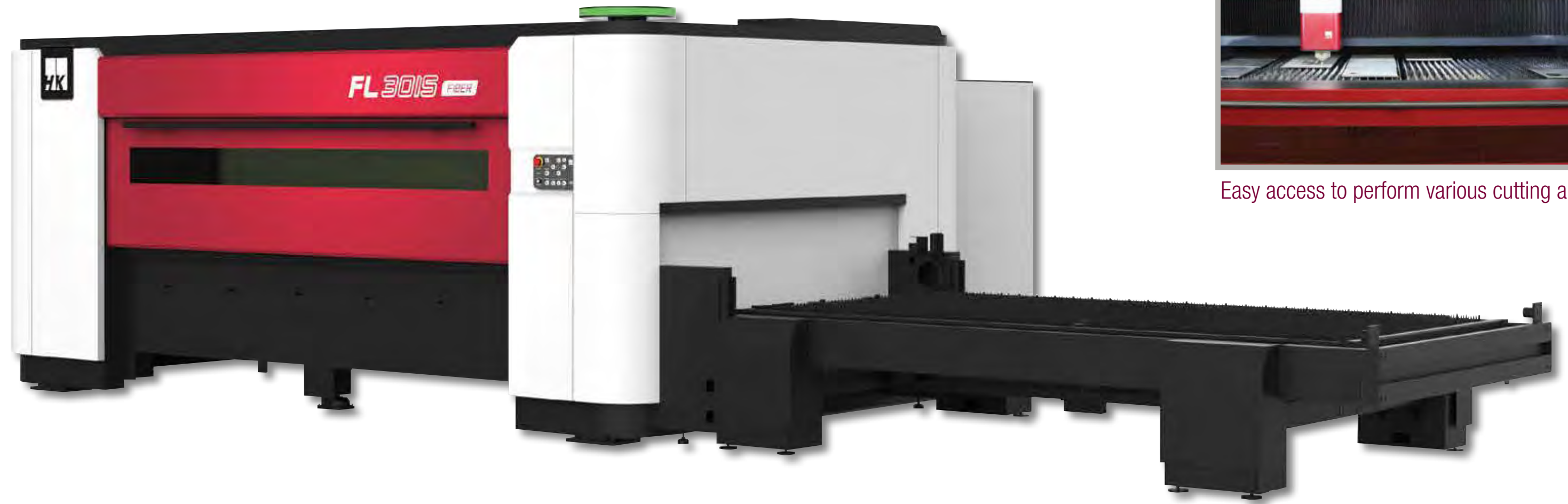

Easy access to perform various cutting applications

Rotary Axis Package for Tube Cutting (optional)

- Rotary axis package consists of rotary axis, tailstock, and tube support. It is capable of handling a tube diameter of up to 11.8" O.D. It also has a feed-thru hole which can feed tubes up to 6.0" in diameter.
- Attached at the left side of the frame with the tube running parallel to the length of the table. Operator can easily load the material from the front door as well as pick up the cut tubes using the wide open side door.
- Able to cut round, square, and rectangle tubes.

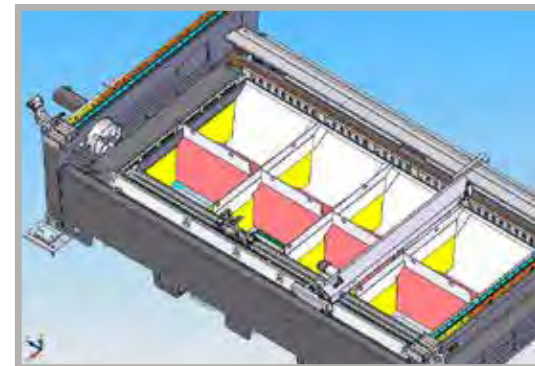

Smart-Cut Technology

- Thanks to the newly developed unique nozzle system, zoom cutting head technology and special DB, the FL3015 6kw Fiber creates a pristine cut for 3/4" mild steel and 5/8" stainless steel

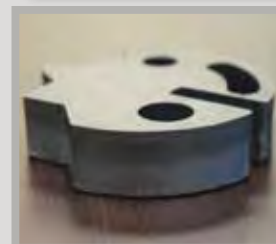

Air-Cutting Package

- 3rd air-port line for shop air in addition to current Oxygen and Nitrogen lines
- Field proven air-cutting database ready to use
- Cutting speed as fast as Nitrogen cutting
- Turnkey package for 3rd party HP air-booster and filtration system (optional)



HK Zooming Head for Spot-Size Change

- Automatic spot size variable from small spot size to big spot size
- Automatic programmable change for focus position
- Zoom head provides much wider sweet-spot for optimal cutting when cutting thick plates of mild steel or stainless steel
- No need to change the lens cartridge which eliminates risk of fatal contamination issues at the cutting head

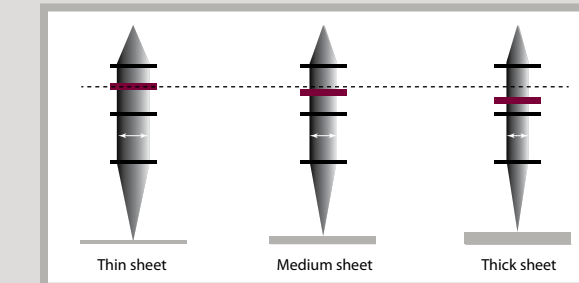

High Speed 15" Siemens 840D Control & Drive

Stand-type operator control console with 15" touch panel screen. Powered by Siemens 840D SINUMERIK control & drive, it enables unbeatable high speed processing with 80GB hard disk and 2GB memory size. Its intuitive HMI screen with built-in tech database makes operator easy to learn and run the control and machine



HK Automation Solutions

Smart-Cell

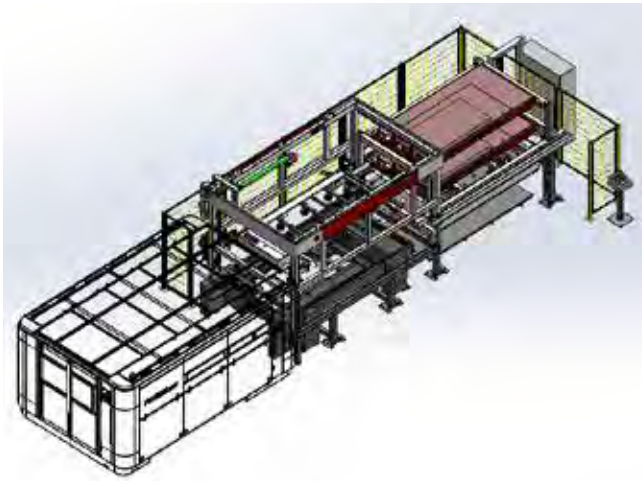

- Fully automatic extended Load/Unload System
- Two shelves for loading / One shelf for unloading
- 60 second cycle time

Smart-Tower I

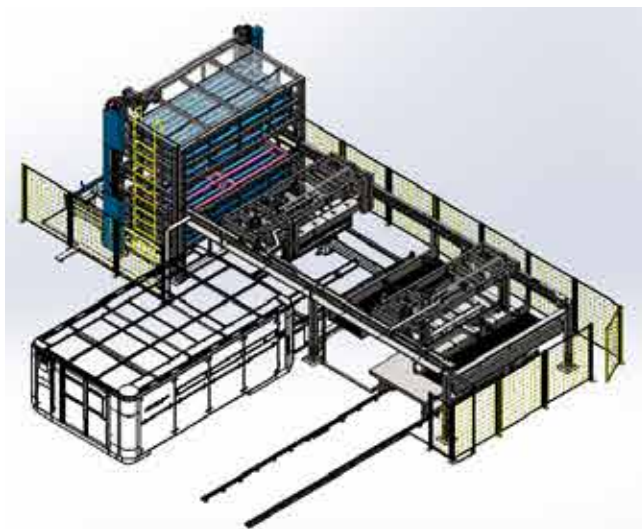

- Tower and unloading table are independent, cut sheets are placed on unloading station
- Unloading station is pre-programmed to slide over the embedded rail
- 8 shelves for 24/7 production

Smart-Lifter

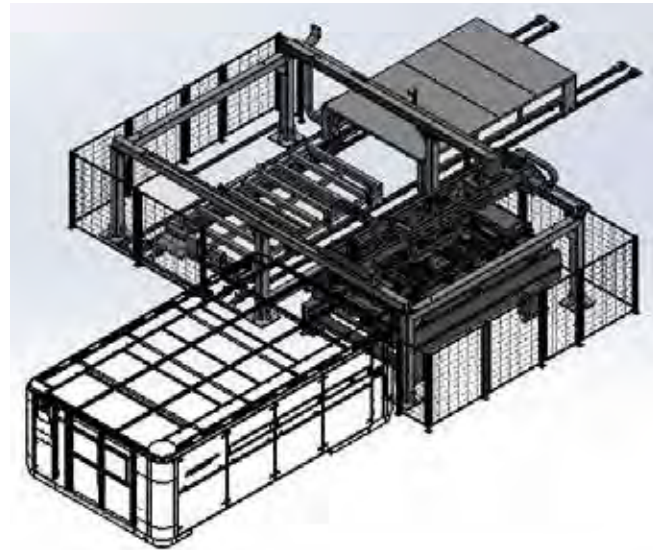

- Hydraulic Cylinder & Dual guide bars
- 18 suction cups with flexible layouts
- Solid & tough frame for heavy plates

Smart-Tower II

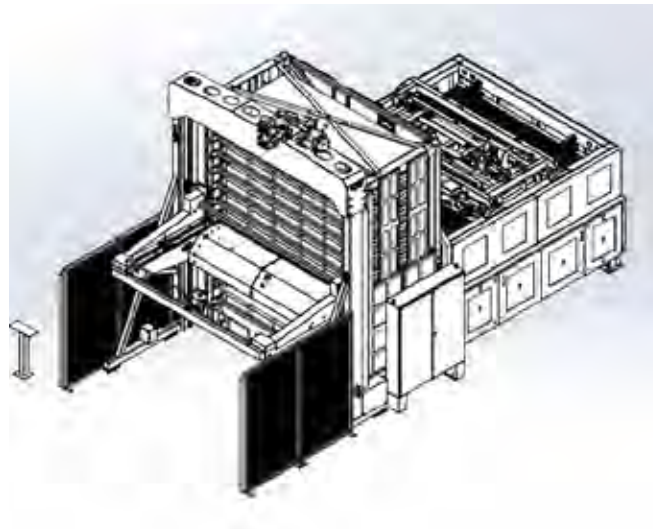

- Out-Cycle time: 60 seconds
- Exchange cycle for 1 tray approx., 120 seconds
- 8 shelf tower for both raw material and cut sheets

TECHNICAL SPECIFICATIONS

Items	Specifications	Remarks
Laser Power	3.0KW, 4.0KW, 6.0KW	IPG Photonics
Max. Cutting Size	60" x 120"	
Positioning Speed	5500 IPM	X and Y axis combined
Max Cutting Speed	1890 IPM	
Accuracy	±0.0039"	Over 120" Travel
Repeatability	0.001"	
Controller	Siemens 840D	
Cutting Head	F150	Zooming Head Optional

* Specifications are subject to change without notice.

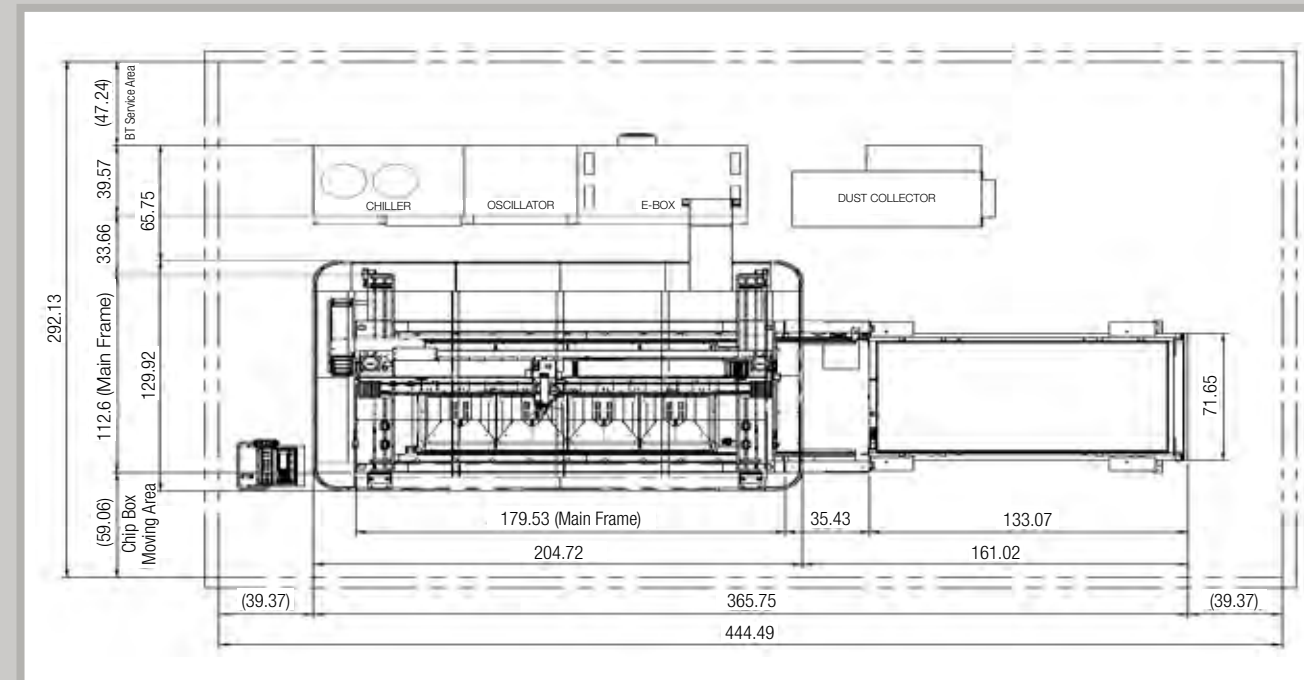

HK AMERICA, Inc. • 1120 North Garfield Street • Lombard, IL 60148 • PH 630.916.0200 • hk-us.com • sales@hk-global.com

Distributor



FL3015 FIBER

Featuring a Wide-Open Side Door with a Long Gantry Cutting Bridge

